



3-Pole Contactors

30-50 HP (460V)

48-68 FLA

Contactor catalog numbers are shown in the shaded area in the **Contactor Selection and Data** table. To complete the catalog number, replace the symbol (* or †) with the appropriate digit from the shaded area in the **Coil Selection** table. Additional coil information is shown in the **Coil Data** table.

Contactor Selection and Data		Hp @ 460V AC-3 (kW @ 380V, 415V, 50 Hz)		
		30 hp (22 kW)	40 hp (30 kW)	50 hp (37 kW)
AC Contactors	Full Voltage Non-Reversing	CL06A311M*	CL07A311M*	CL08A311M*
	Reversing	LAR06A*	LAR07A*	LAR08A*
AC/DC Electronic Contactors	Full Voltage Non-Reversing	CL06E311M†	CL07E311M†	CL08E311M†
	Reversing	LER06A†	LER07A†	LER08A†
Aux. Contacts	Maximum Aux. Contacts	8	8	8
	Maximum Contact Block Configuration	6 Front-Mount plus 1 Side-Mount, or 2 Side-Mount on each side		
Aux. Contacts (A600, Q600) ¹		1NO-1NC	1NO-1NC	1NO-1NC
Continuous Amp Rating (UL)		80	100	110(O), 102(E)
AC-1 Amperes (IEC)		80	100	110
AC-2/AC-3	Max. FLA	48	62	68
	Max. Hp (1-Phase)			
	115 Volts	3	5	5
	230 Volts	7.5	10	15
	Max. Hp (3-Phase)			
	200 Volts	15	20	20
230 Volts	15	20	25	
460 Volts	30	40	50	
575 Volts	40	50	60	
AC-4 Max. Hp	200 Volts	15	20	20
	230 Volts	15	20	25
	460 Volts	30	40	50
	575 Volts	40	50	60
Mechanical Life (millions of operations)		15	15	15
Elec. Endurance (AC-3) At Rated Current (millions of operations)		1.8	1.7	1.5
Maximum Operational Current 460V and Below	AC-1 ≤ 1200 ops./hour	80	100	110(O), 102(E)
	3000 ops./hour	40	50	55(O), 51(E)
	AC-3 ≤ 1200 ops./hour	48	62	68
	3000 ops./hour	16.8	21.7	23.8
Net Weight	Contactor	2 lb. 7 oz.	2 lb. 8 oz.	2 lb. 8 oz.
	Class 10 Overload Relay	13 oz.	13 oz.	13 oz.
Wire Size - Power Terminals 75°C (Cu) AWG		14-1/0	14-1/0	14-1/0
Torque (Main) in.-lb.		50	50	50
Noise (dba)		45	45	45

¹ Two Front-Mount auxiliary contacts are supplied. Add the suffix "S" to catalog number for Side-Mount auxiliary contact.

Note: (O) = Open, (E) = Enclosed

Coil Selection (AC)

AC Voltage		Coil * Suffix
60 Hz	50 Hz	
24	24	1
48	42	F
120	110	J
208	—	L
277	220/230	N
240	—	S
480	380/400	U
—	415	W
600	500	Y

Coil Selection (AC/DC Electronic)

AC (50/60 Hz) DC Voltage	Coil † Suffix
24-28	D
42-48	F
110-127	J
220-250	N
440-500	Y

Coil Data

	AC Voltage	AC/DC Voltage
Burden		
Inrush	191 VA	125 W
Holding	17 VA	2.5 W
Pick-up Voltage (% Of Coil Volts)	85-110	80-110
Drop-Out Voltage (% Of Coil Volts)	40-60	40-60
Switching Delay (ms)		
Switching Delay On		
Coil Voltage at +10% to -20%	9-35	60-80
Coil Voltage At Rated Value	15-30	50-60
Switching Delay Off		
Coil Voltage at +10% to -20%	9-15	40-50
Coil Voltage At Rated Value	9-15	55-60
Maximum Operations per Hour		
No Load	9000	2500
Rated Load — AC1, AC3	1200	1200
Rated Load — AC4	200	200

REFERENCES

Standards and Listings	Page 41
Overload Relays	Pages 26-29
Accessories	Pages 30-37
Life Curves	Pages 42-44
Additional Coil Information	Page 37
Instruction Sheet	GEH-6225
UL File Number	E76233
CSA File Number	LR30821

3-Pole Contactors 30-50 HP (460V) 48-68 FLA

Legend and Notes for Illustration

- Ⓐ Extra Auxiliary Contacts, Side Mounted (if used)
- Ⓑ Extra Auxiliary Contacts, Front Mounted (if used)
- Ⓒ Pneumatic Timer (if used)
- Ⓓ Mechanical Latch (if used)
- Ⓔ Transient Voltage Suppressor

Add ½ inch for electrical clearance to enclosure.

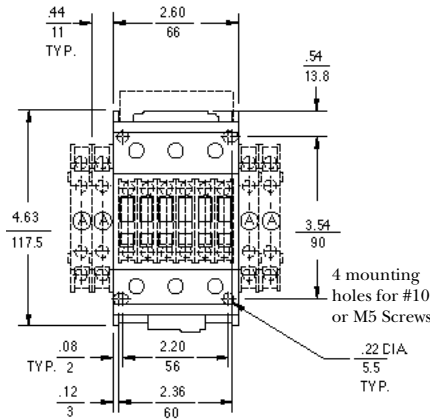

Contactor - Front View



Starter - Front View

Engineering Outline Drawings

AC

Contactor	55-215784
Starter	55-215828
Reversing Contactor	55-215794
Reversing Starter	55-215795

AC/DC Electronic

Contactor	55-216213
Starter	55-216209
Reversing Contactor	55-216212
Reversing Starter	55-216216

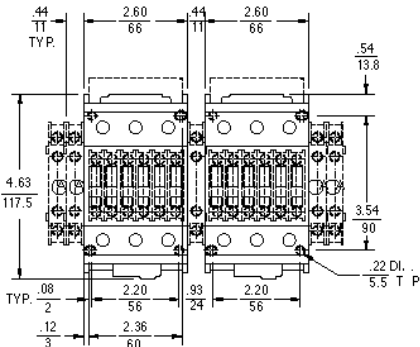

Reversing Contactor - Front View

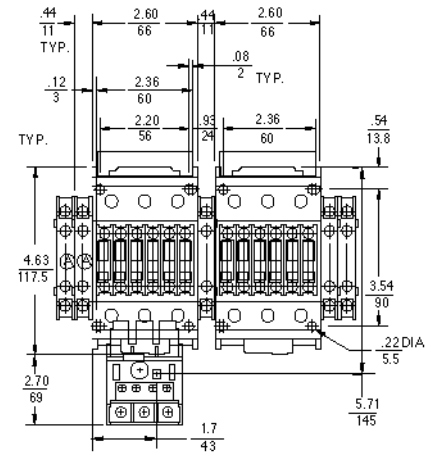

Reversing Starter - Front View

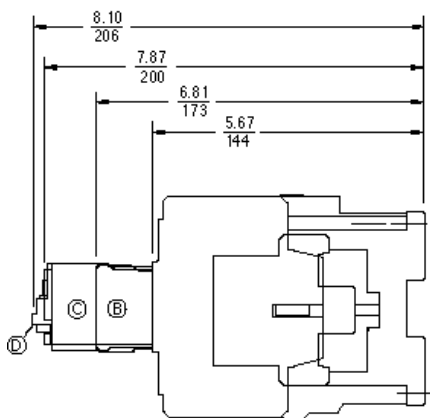

AC/DC Contactor - Side View

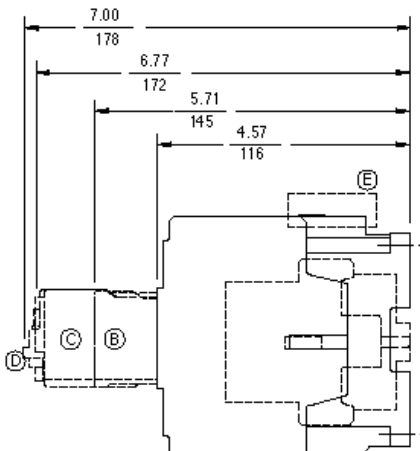

AC Contactor - Side View

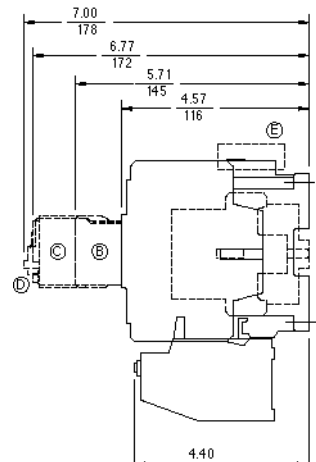

AC Starter - Side View